

Patent No.: US 11,554,772

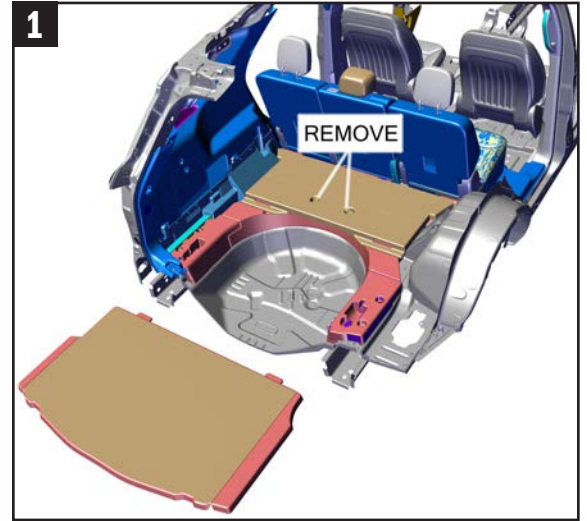

- 1 • Remove the flooring from the cargo area.
- Remove the (2) bolts to remove the forward flooring.

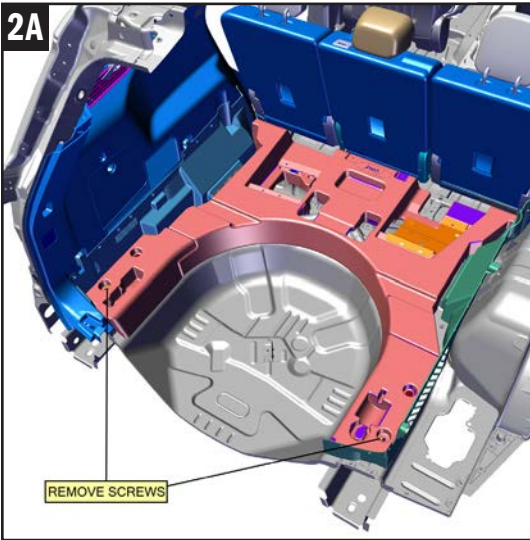

- 2 • Remove the (2) 8 mm bolts holding the end foam pieces in place.
- Unclip the wire harness and remove the cover plate to remove the upper foam from the vehicle.
- Remove the OEM solid foam core from the Cargo Area in two sections.

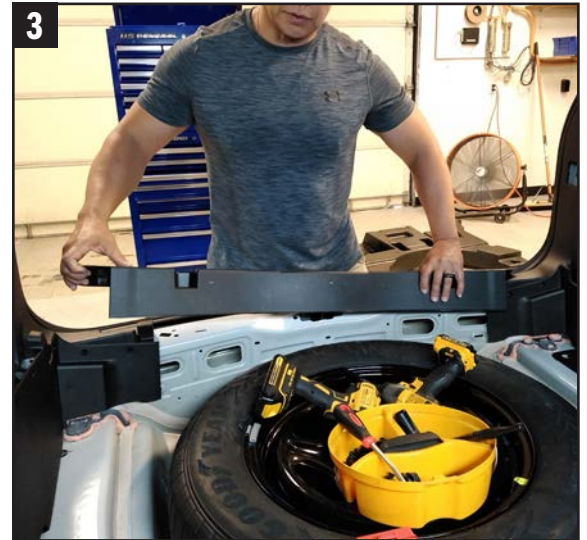

- 3 • Pry around the edges of the rear lower cargo trim to separate it from the cargo compartment. Trim removal tool required.



- 4 • Remove the lower side panel from the upper side panel secured with (14) press in plastic clips.



**5** Unscrew the accessory hatch cover pin from the rear of the cargo upper trim.



**6** · Pop loose the (2) press in pins holding the panel to the lower seat skirt fabric, remove trim section.  
· Fold the rear seats down and pull the rubber door seal away from the "C-Pillar" side panel.

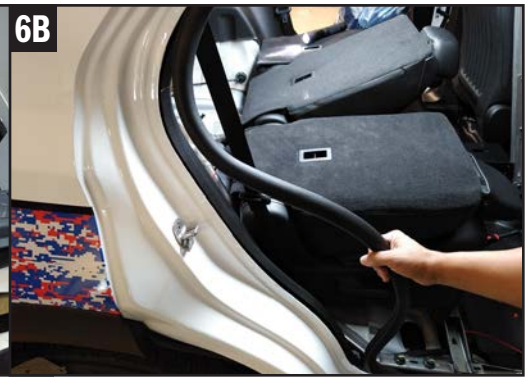

**7** Starting from the cargo area, pop loose the upper panel while moving forward to the rear seat area. Once loose, remove from vehicle.

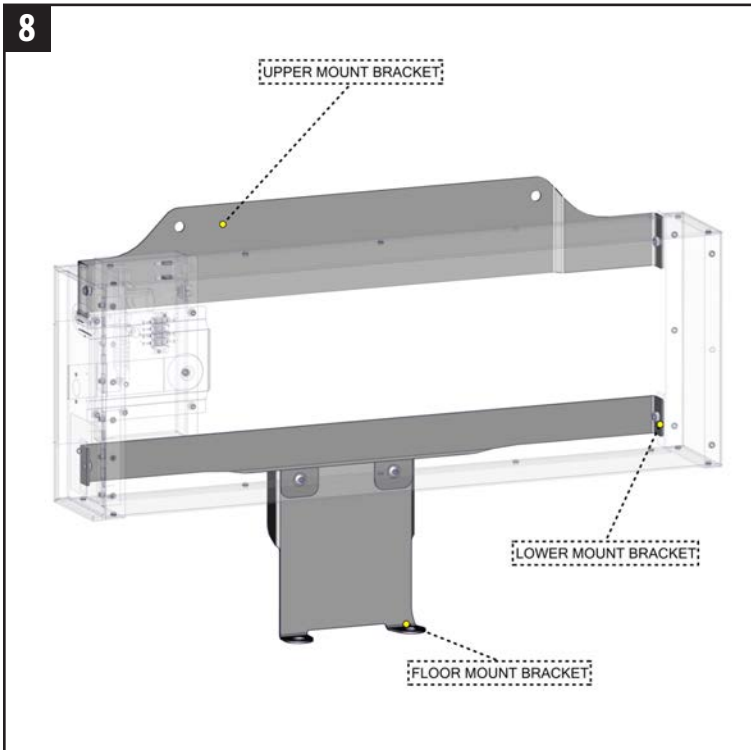

**8** Attach the Upper Mount Bracket and Lower Mount Bracket to the Gun Box, then the Floor Mount Bracket to the Lower Mount Bracket with (6) socket head cap screws.

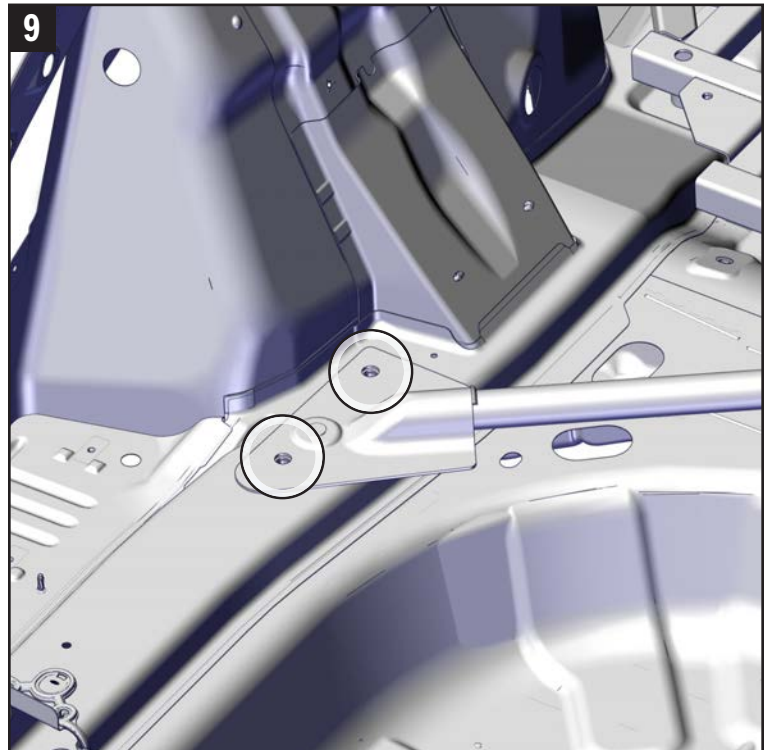

**9** Remove (2) OEM 18 mm bolts from the OEM cross-brace support. Install the assembled Gun Box assembly into the vehicle and secure with previously removed bolts.

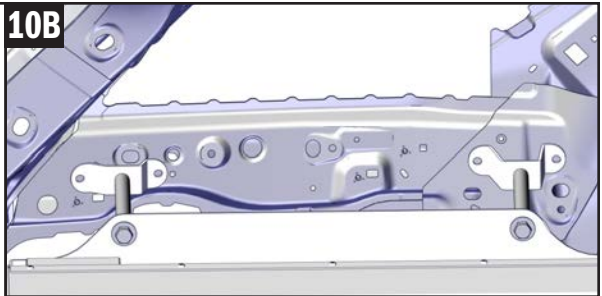
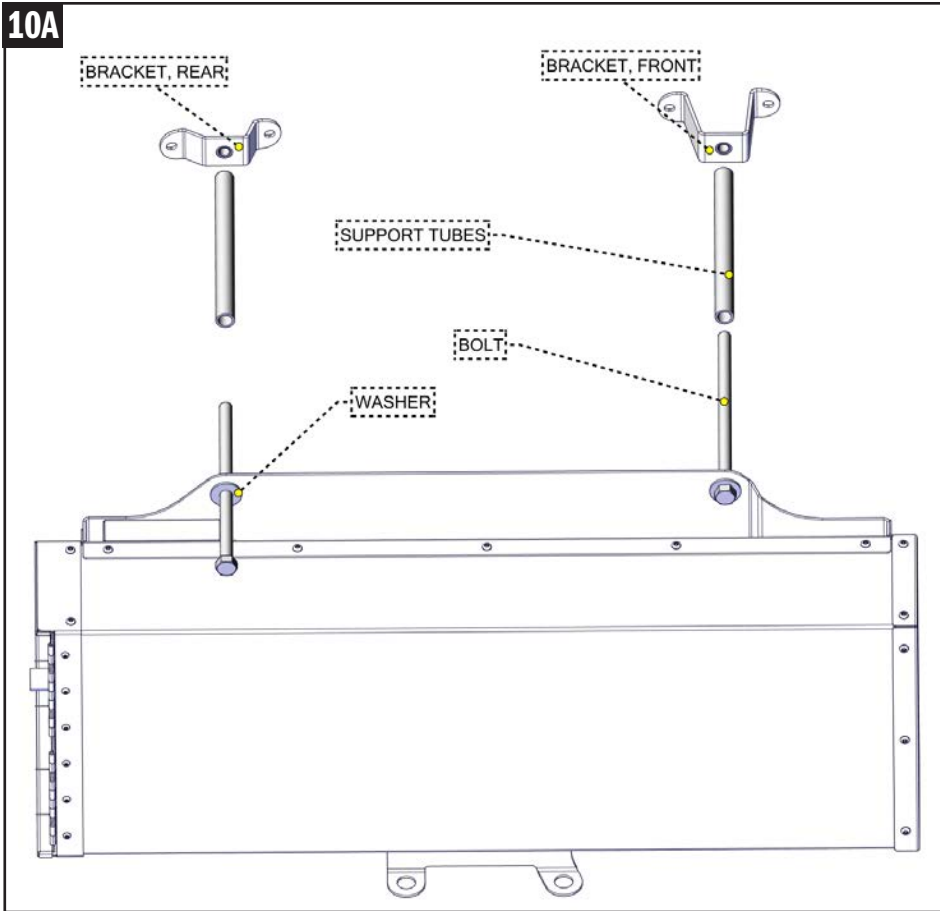

- 10**
- Securely attach the Front Bracket and Rear Bracket to the Gun Box with supplied hardware. (2) Support Tubes, Bolts and Washers.
  - Press the Front and Rear Brackets against the internal metal structure of the cargo area. Mark drilling points for each bracket. "Brackets, wire harnesses, and clips may have to be repositioned then replaced for this step."

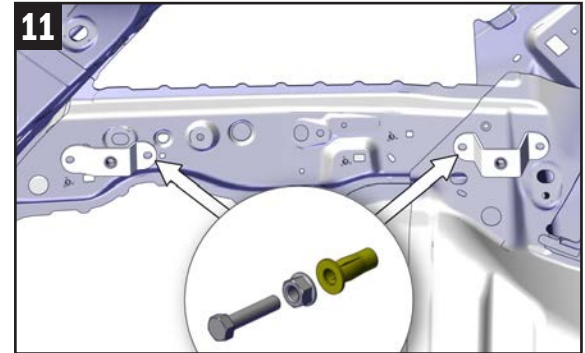

- 11**
- Uninstall the Gun Box from the vehicle giving you enough room to drill and install brackets. Follow the instruction guide on how to secure AVK fasteners.

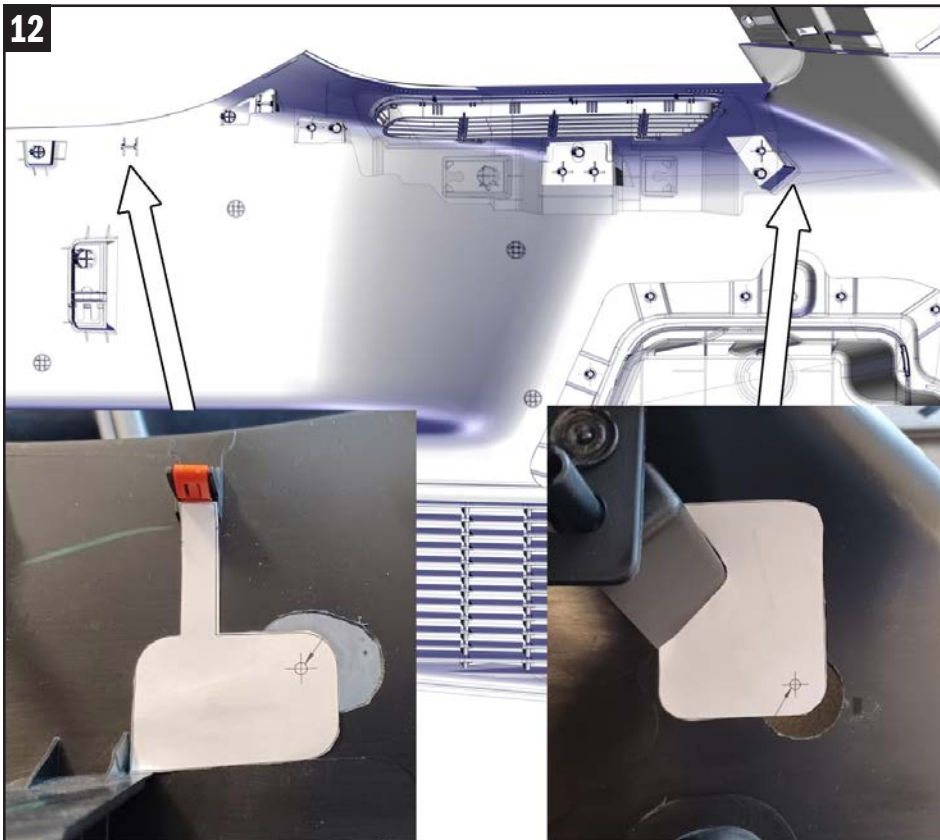

- 12** Print off 1:1 Drill Template, cut out and align with points shown. Drill a 1/8 pilot hole followed by a 1 inch hole.

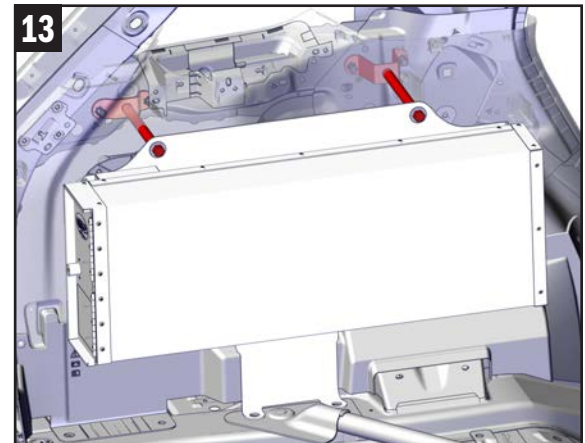

- 13** Reinstall the upper and lower trim sections into the vehicle. Reinstall "The Stash" Gun Mount to the cross-brace support with 18 mm bolts, and the Upper Mount Bracket through the drilled trim to the Forward and Rear Brackets with supplied hardware.

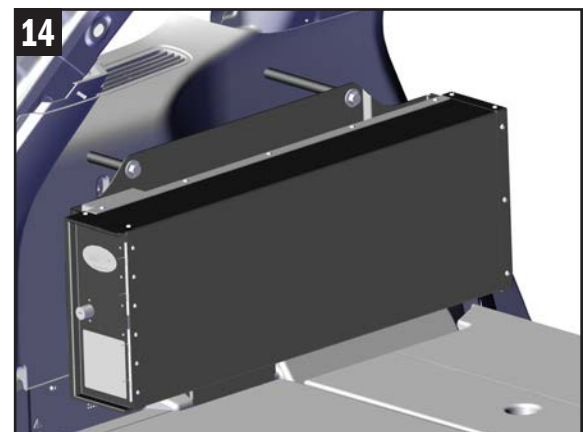

- 14** Reassemble cargo area and secure all hardware.

# GUN BOX WIRING DIAGRAM (HOOKUP HARNESS)

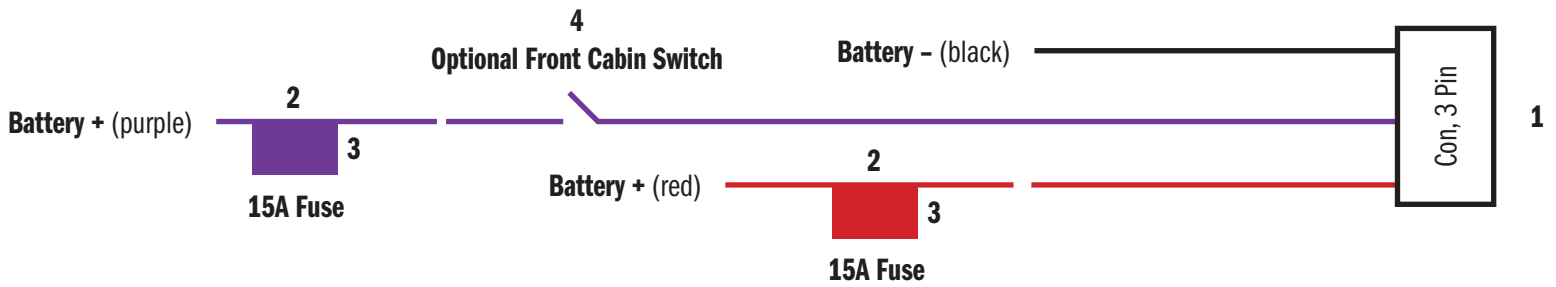

\* - Battery connection can be Switched or Constant based on the desired function. Ignition **ON** or **OFF** function.

1 = 475-2111, Harness, Gun Box, External

2 = 450-0105, Holder, Fuse, In-Line, ATC

3 = 450-0199, Fuse, 15A, ATO-ATC

4 = 475-7208, Momentary Switch

## AVK Fastener Installation Instructions

AVK Installation video can be viewed at:

<http://jottopublicsafety.gojotto.com/additional-categories/downloads.html>



1. Drill out existing hole to 1/2" or drill new hole per installation instructions.



2. Place 5/16-18 x 1.5" long bolt through the 3/8" flange nut and hand thread bolt into the AVK Fastener.



3. Place into 1/2" drilled hole.

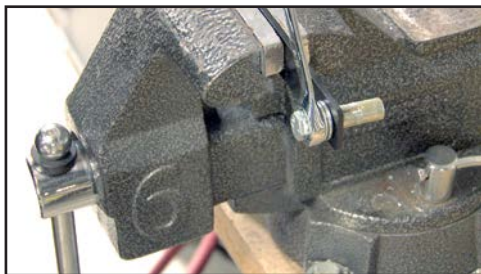

4. Use 9/16" box end wrench to secure the flange nut.



5. Apply pressure on the flange nut, pressing AVK Fastener into hole.
6. Using an air wrench, tighten the 5/16-18 x 1.5" bolt.



7. This will allow the AVK Fastener to secure onto the backside of the metal.
8. Remove 5/16-18 x 1.5" bolt.

If you have questions or need further assistance please call Technical Support: 1.877.455.6886



209 W. EASY ST., ROGERS, AR 72756 • JOTTOPUBLICSAFETY.COM • 11/23

Jotto Desk™ is a patented product and Registered Trademark of Assembled Products™ Corporation.  
Specifications subject to change without notice.

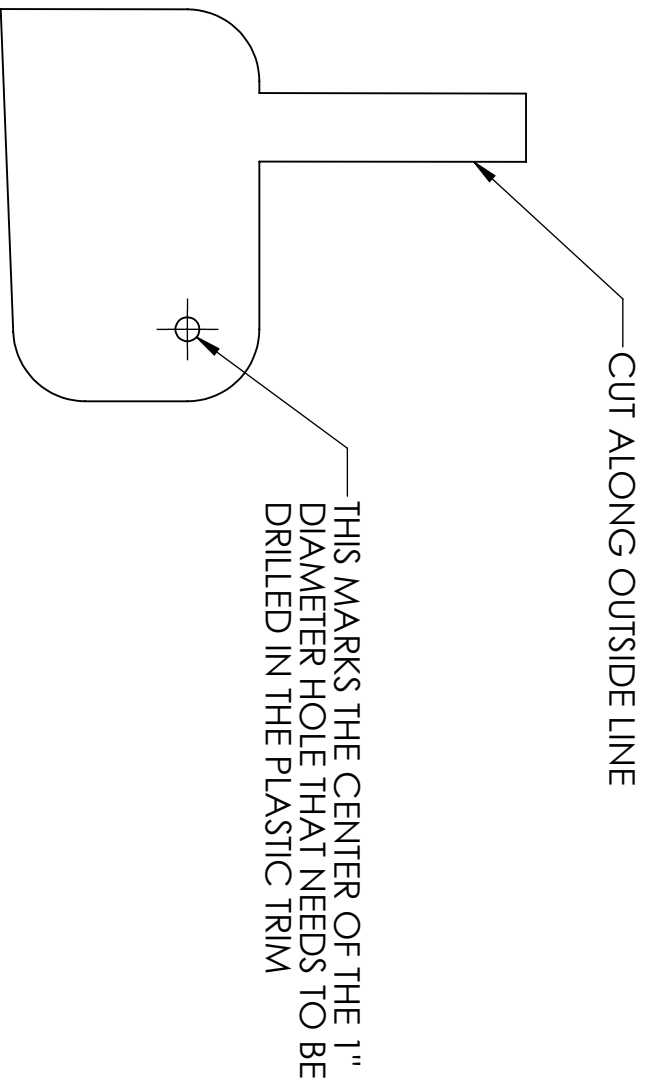

CUT ALONG OUTSIDE LINE

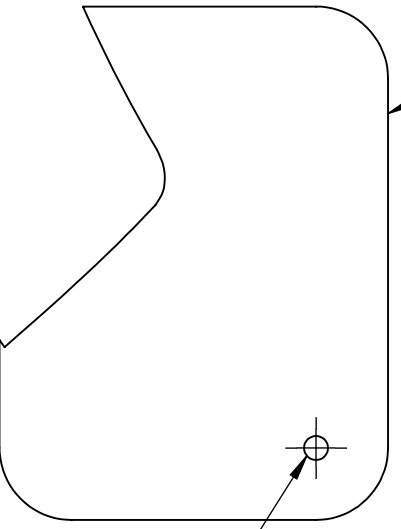

THIS MARKS THE CENTER OF THE 1" DIAMETER HOLE THAT NEEDS TO BE DRILLED IN THE PLASTIC TRIM