



SINGLE CELL LITE

FORD PI UTILITY (2020+)

Installation Instructions

475-0791

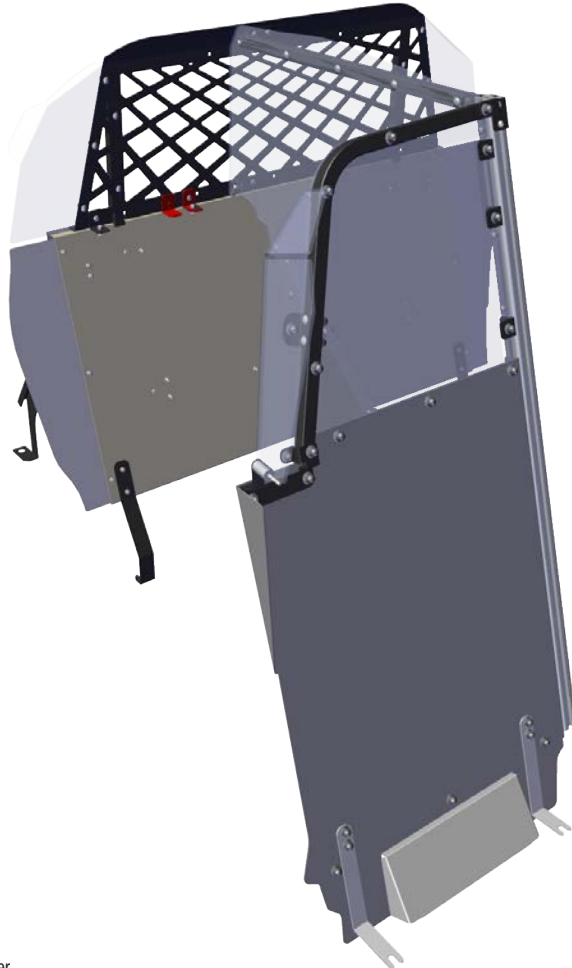

Tube Brackets



Mount Brackets

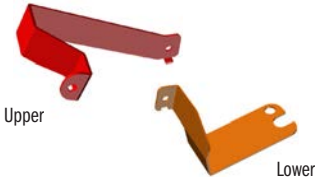

Mounting Feet

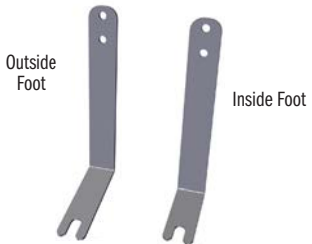

B-Pillar Bracket



Center Stiffener Tube



Poly Wing



Assembled Front Divider



Lower Steel Center Divider



Upper Poly Center Divider

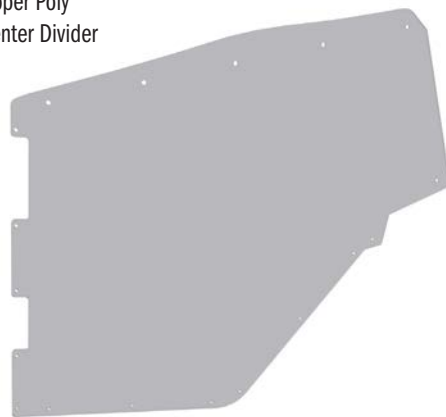

HSEP

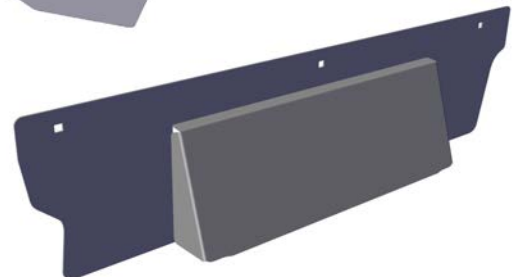

INSTALL CARGO BARRIER NOW

* SEATS MUST REMAIN UPRIGHT DURING INSTALLATION



1. Remove OEM flooring starting at the hatch. This portion can simply be pulled out.
2. Remove the (2) bolts to remove forward flooring and set aside for replacement.

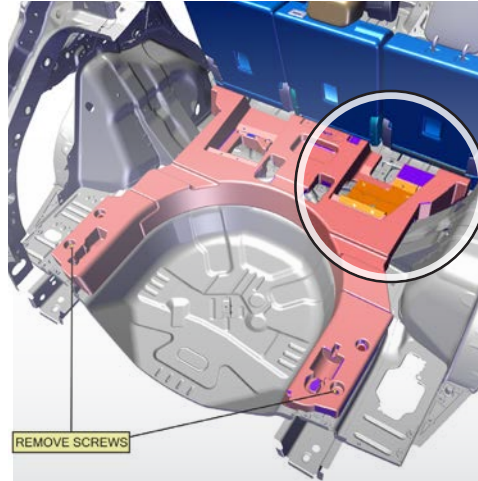

3. Remove the (2) 8 mm OEM bolts holding the end pieces in place.
4. Unclip the wire harness and remove the cover plate to remove the upper foam from the vehicle. Once Cargo Barrier is installed, this will be reinstalled into vehicle.
5. Remove OEM solid foam core from cargo area in 2 sections.



6. Install DS/PS Outer Mount Brackets to the OEM 13 mm rear seat bolts and the DS/PS Rear Mounts Legs into vehicle by removing OEM 18 mm bolts, located on the vehicles lower rear cross brace.
7. Install the "Single Cell" Lower Mount Bracket to the OEM Cross Tube with existing 15 mm bolt.
8. Install Lower Steel Barrier through rear of vehicle.
9. Attach the Support Tube to the D/S of the Lower Steel with provided carriage bolts and flange nuts

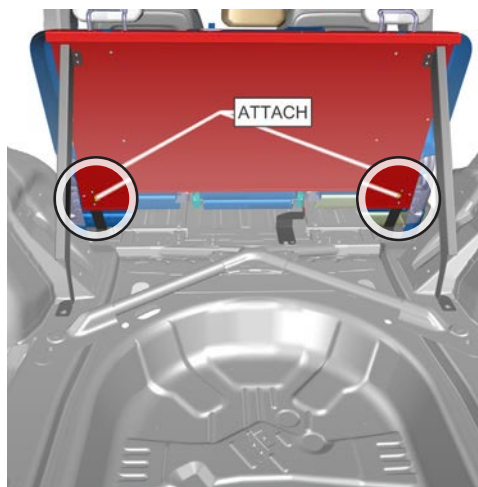

10. Insert the "Single Cells" Upper Mount Bracket in-between the rear seats from the Passengers side.
11. Attach to the Lower Mount Bracket to the Upper Mount Bracket from the cargo area with provided hex bolt.

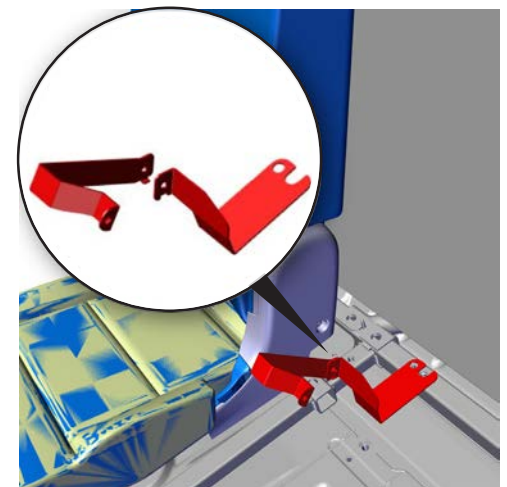

12. Reinstall OEM solid foam core and OEM flooring. Secure in place with previously removed (2) OEM bolts.

* **DO NOT ATTACH YET.**

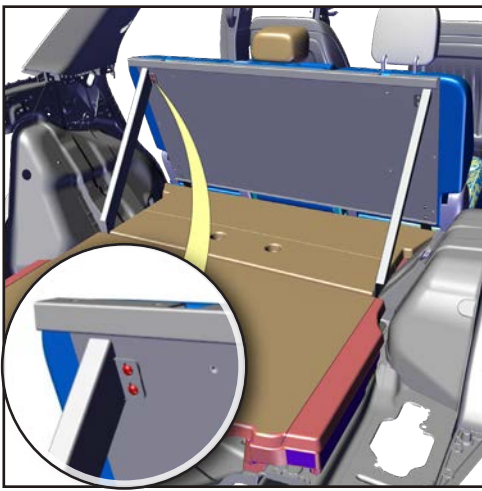

13. Outside of vehicle, attach the Stiffener Tube to the D/S Upper Poly Center Divider with provided carriage bolts and flange nuts.

* You can now attach DS/PS Rear Mount Legs to Lower Steel Barrier with provided Button Head Cap Screws.

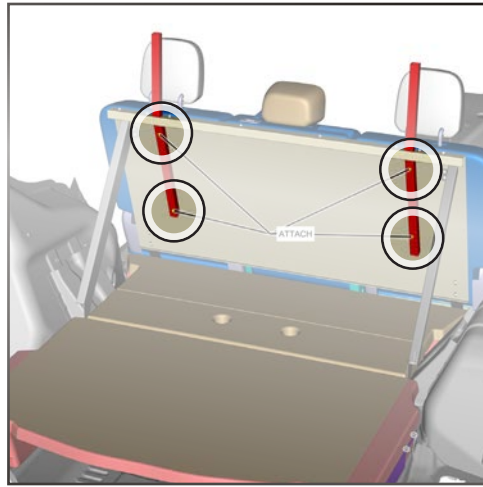

14. From rear seat of vehicle, use button head cap screws to attach Secure Grid to Lower Steel Barrier and (4) carriage bolts and flange nuts to the Support tubes.

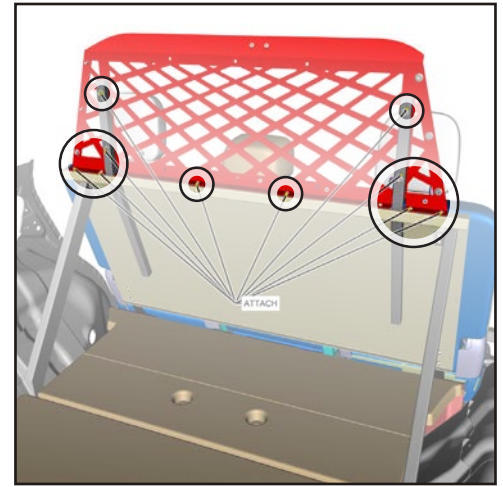

15. Install Lower PS/DS Side Wings with provided hardware to the rear side of the cargo barrier.

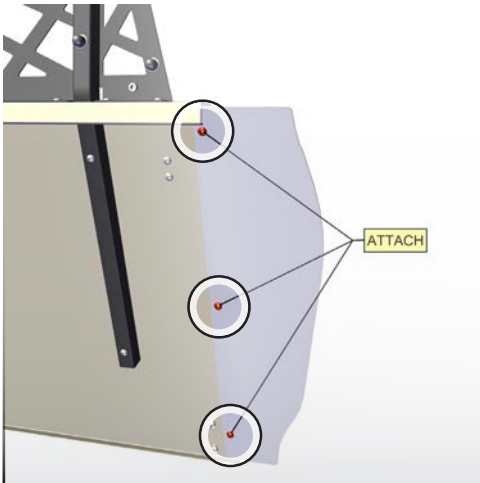

16. Install Side Poly Wings through rear of vehicle. Secure with (3) carriage bolts with flange nuts.

* 475-0067 installation complete.

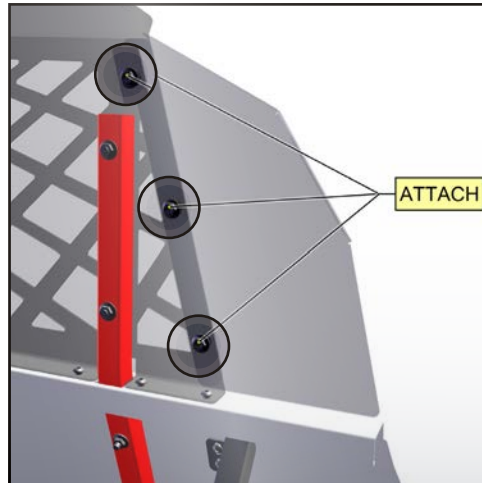

INSTALL SINGLE CELL LITE NOW

(pages 4-5)



1. Loosen the passenger side rear 13 mm seat bolts.

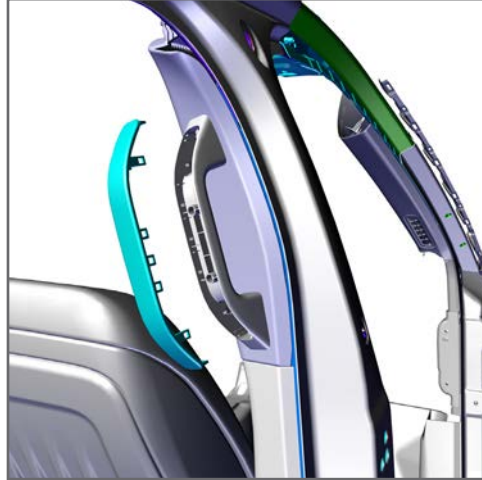

2. Pop the top/bottom cover of P/S rear seat grab handle, exposing (2) 7 mm hex bolts.

3. Remove lower bolt.

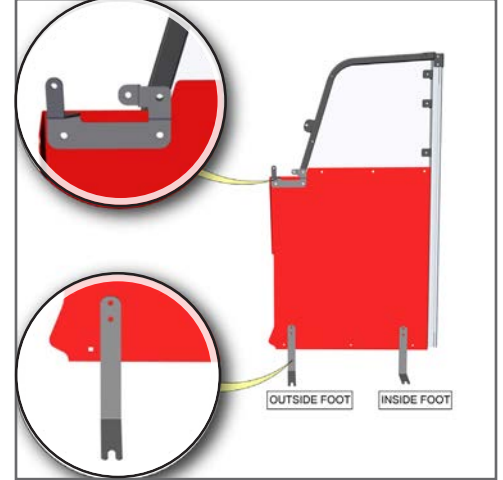

4. Attach the B-Pillar Bracket to the front divider with provided carriage bolts and flange nuts.

** OEM COVERS CAN BE LEFT OFF OR THEY CAN BE TRIMMED DOWN TO BE REINSTALLED.*

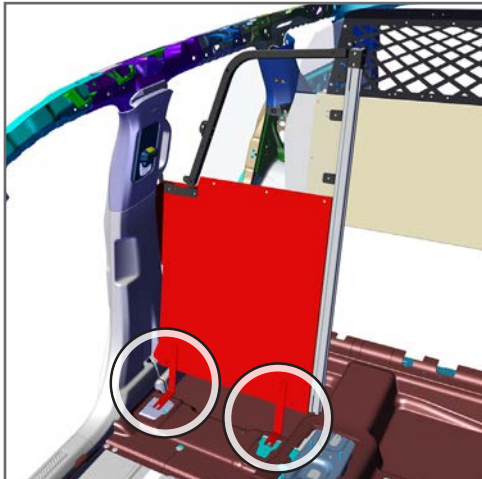

5. Install the Assembled Front Divider into the vehicle through P/S rear door.

6. Insert the Lower Mount Feet under the seat track and aligning with the rear seat bolts.

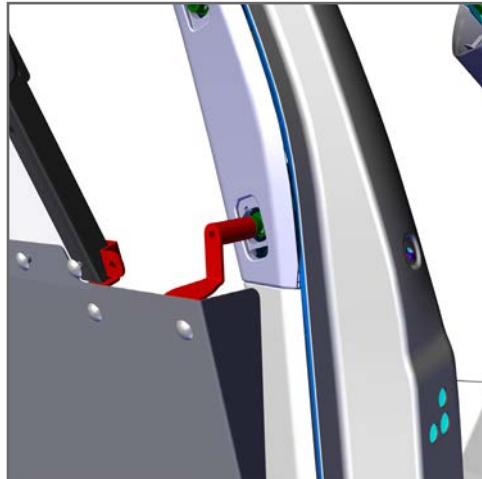

7. Attach B-Pillar Bracket to lower grab handle mount with provided spacer and hardware.

8. Tighten OEM rear seat bolts securing Assembled Front Divider into place.

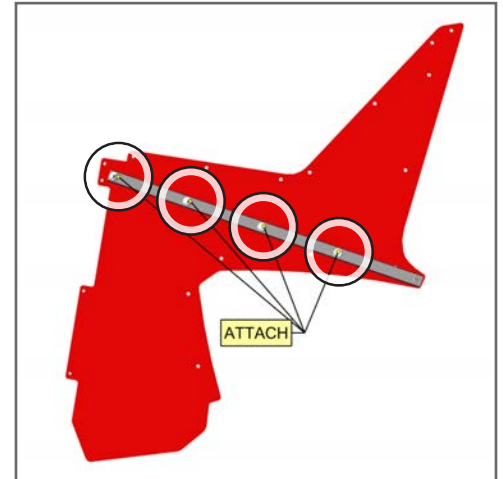

9. Attach Support Tube to the Center Lower Steel with provided carriage bolts and flange nuts.

** Last hole will not have a carriage bolt until being attached to Upper Mount Bracket previously installed between the seats.*

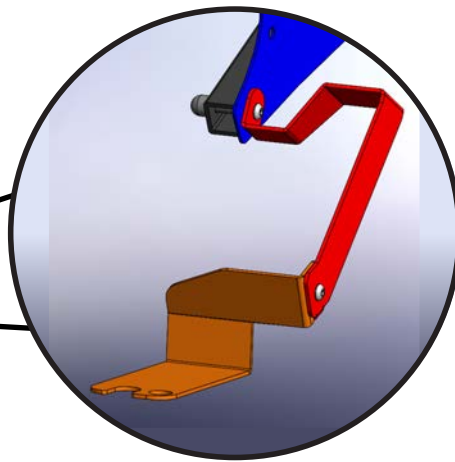
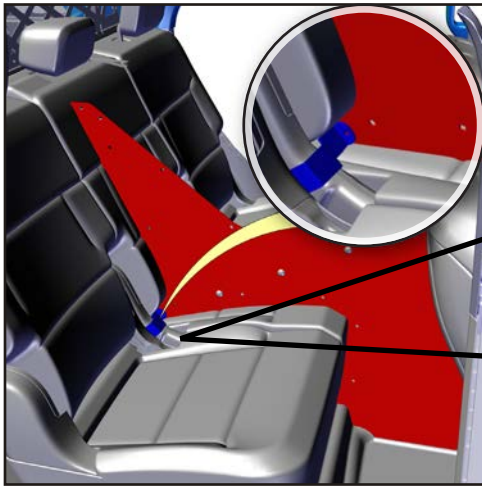

10. Insert the Lower Steel Center Divider into the vehicle through the D/S door wrapping the tabs around the backbone at the front and securing with button head cap screws.
11. Secure the Lower Steel Center Divider to the to the Upper Mount Bracket at the rear with carriage bolt and flange nuts.

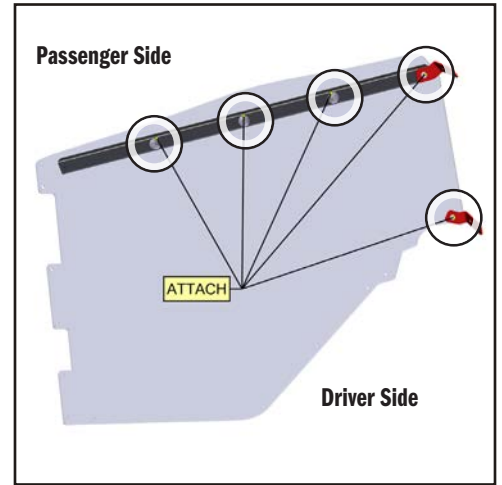

12. Peel protective film from Upper Poly Center Divider.
13. Attach Stiffener Tube to D/S of Upper Poly Center Divider using provided carriage bolts and flange nuts.
14. Secure the Tube Brackets to the end of the Poly Divider and one to the tube with socket head cap screws.

* Front of the tube will not have hardware until next step.

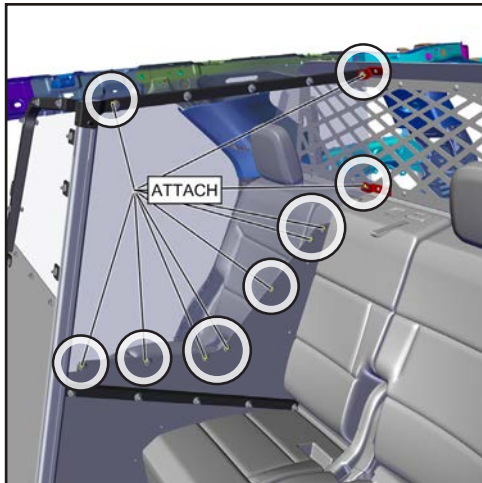

15. Attach Upper Poly Center Divider to the Lower Steel Center Divider with provided carriage bolts and flange nuts.
16. Secure the Tube Brackets to the Cargo Barrier with button head cap screws and the front of the Upper Poly Center Divider Tube to the Assembled Front Divider.



17. Attach Upper Poly Wing to Front Side of Assembled Front Divider near B-Pillar using 1/4-20 carriage bolt and flange nuts in the upper and lower holes of the wing.

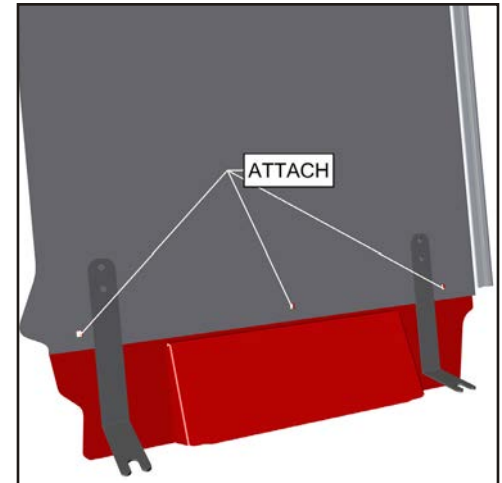

18. Attach the HSEP to the Assembled Front Divider with provided hardware from prisoner compartment.

If you have questions or need further assistance please call Technical Support: 1.877.455.6886



209 W. EASY ST., ROGERS, AR 72756 • JOTTOPUBLICSAFETY.COM • 6/23

Jotto Desk™ is a patented product and Registered Trademark of Assembled Products™ Corporation.
Specifications subject to change without notice.