



# SINGLE CELL CHEVY TAHOE 2021+

## Installation Instructions

475-1711



# SINGLE CELL LITE



Before beginning the installation, confirm that you have received all of the parts for your package.  
Read the instructions completely before starting installation.

# CB4 CARGO BARRIER

Secure Grid Upper Barrier

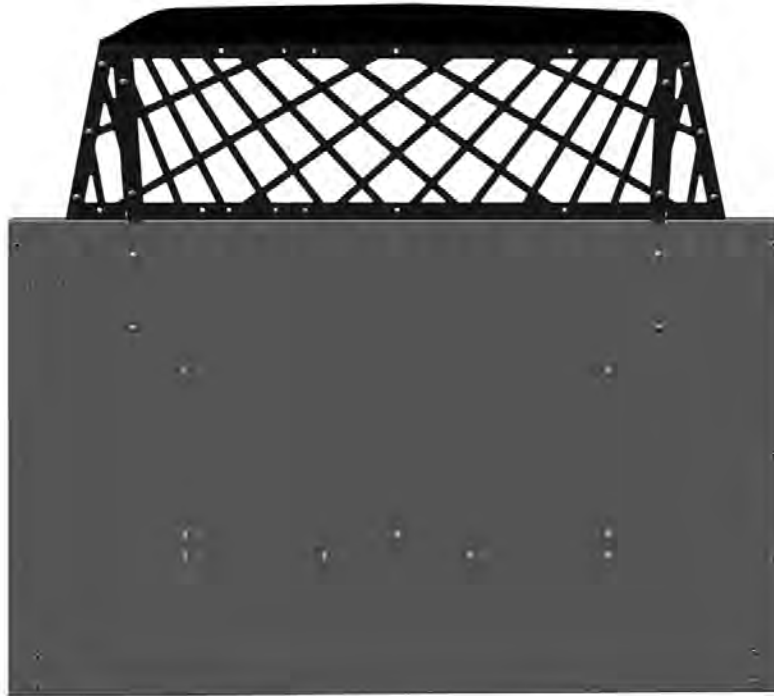

Lower Steel Panel



Before beginning the installation, confirm that you have received all of the parts for your package.  
Read the instructions completely before starting installation.



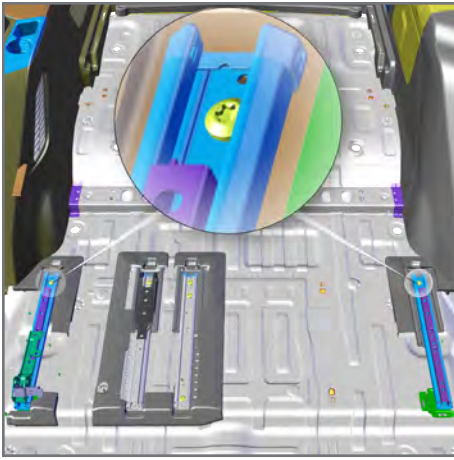

1. Fold both sections of rear seat down and tilt forward. Loosen outer most rear OEM seat bolts.

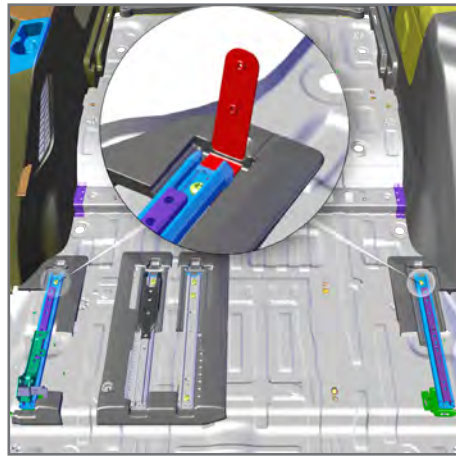

2. Loosely install the DS/PS Lower Mount Brackets under the seat frame.

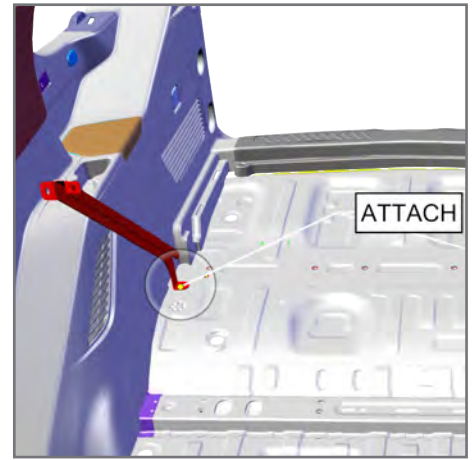

3. Loosely install the DS/PS Rear Mount Legs to the mounting points with OEM hardware.

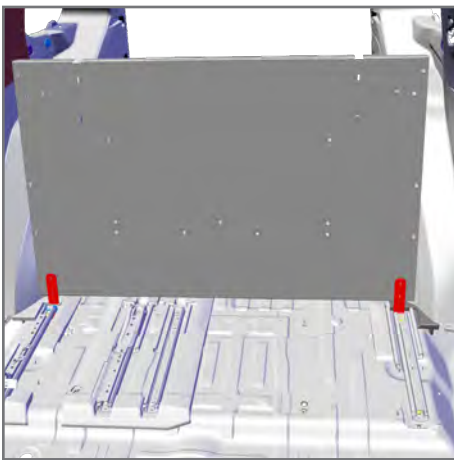

4. Insert Lower Steel Panel through the rear side door. The Rear Mount Legs will support the Steel Panel allowing you to finish installation in the cargo side of the vehicle.



5. Attach the Steel Panel to the previously installed DS/PS Outer Mount Brackets and Rear Mount Legs with provided hex bolts and washers.

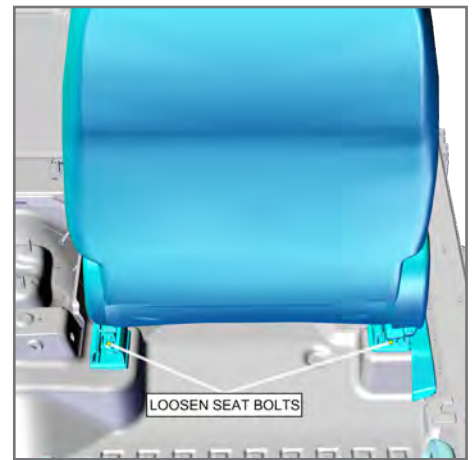

6. Move front passenger seat completely forward and loosen the rear (T-50 Bolts).

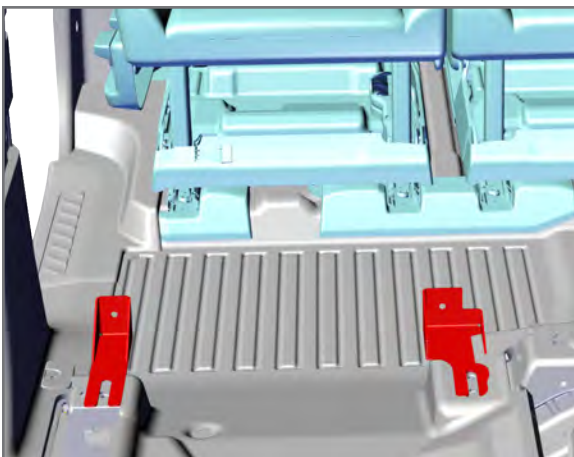

7. Push seat up slightly to slide the Foot Mount Brackets under seat rails, between rail and rubber mat. Leave bolts loose at this time.

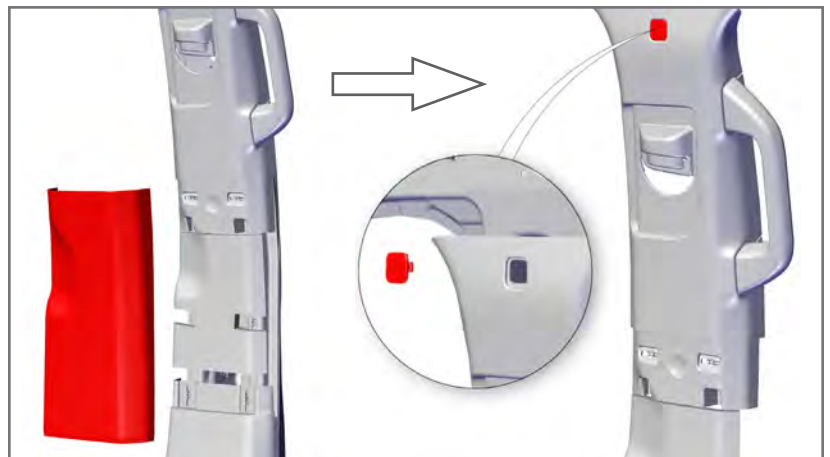

8. With slight pressure, pull to unclip the P/S center "B Pillar trim" from its location and set aside. Remove the upper B-Pillar trim by popping out square trim cover, giving access to the 9/32" screw at the top of the headliner.

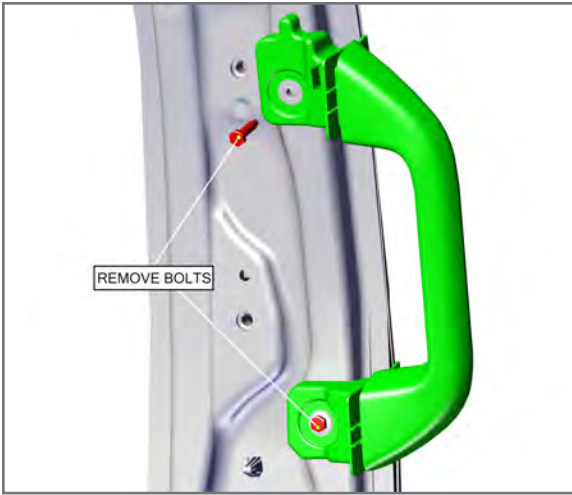

9. Utilize a 10 mm socket to remove the P/S Grab Handle. Grab Handle Not Reused.

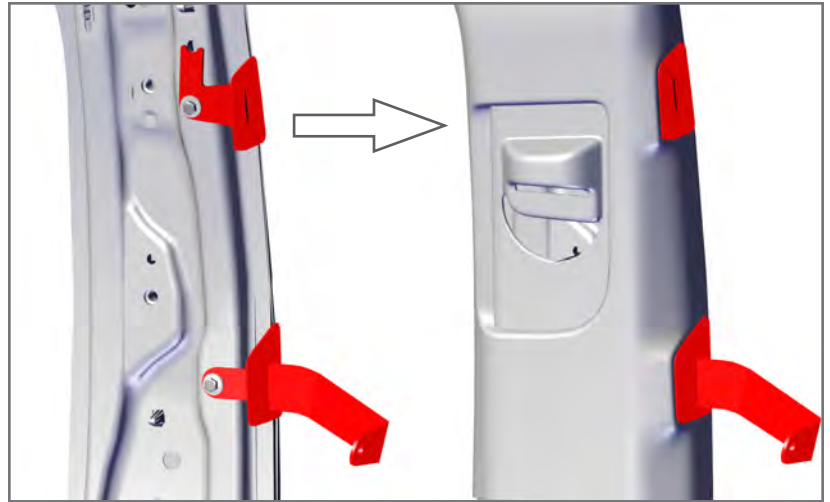

10. Attach the P/S B-Pillar Cover Bracket and B-Pillar Bracket with previously removed 10 mm bolts. Replace upper B-Pillar trim and secure with previously removed 9/32" screw. Finish by snapping back into place the center B-Pillar trim.

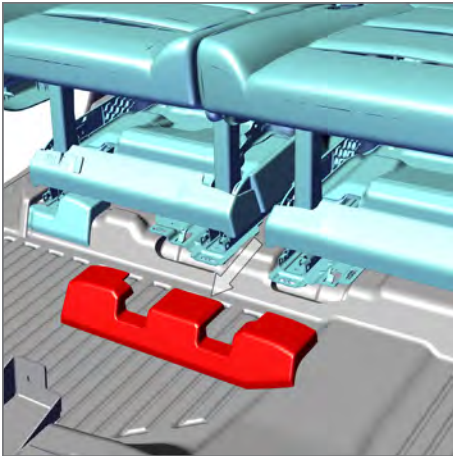

11. Remove lower rear seat rail trim cover and set aside. **Trim not reinstalled.**



12. Fold down and tilt up the D/S rear seat. Remove the OEM screw and pop loose the inside side trim of the P/S rear seat. **Trim not reinstalled.**



13. Loosely attach the ABS Seat Brackets to the ABS Seat with provided carriage bolts and flange nuts.



14. Using a T-47 socket, remove the OEM seatbelt buckle on the inside of the P/S rear seat. Insert the provided Seat Belt Extender through the slot of the ABS Seat. Install ABS Seat into the vehicle and secure the Seat Belt Extender to the previously removed OEM seatbelt location.

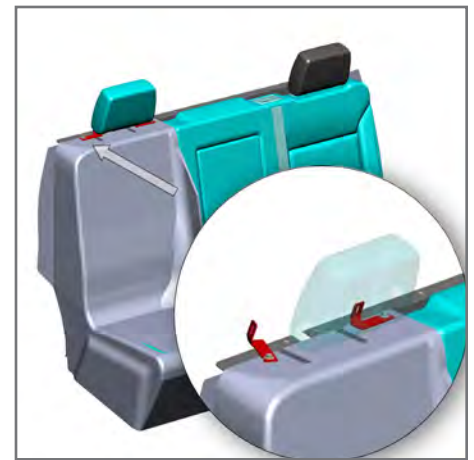
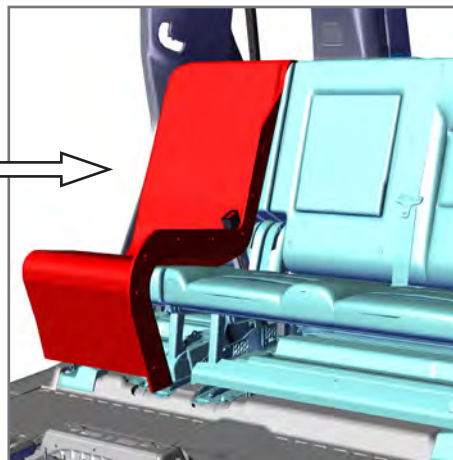

15. Push the top of the ABS Seat through the headrest supports. This may require simple adjustments of the previously mounted ABS Seat Brackets.



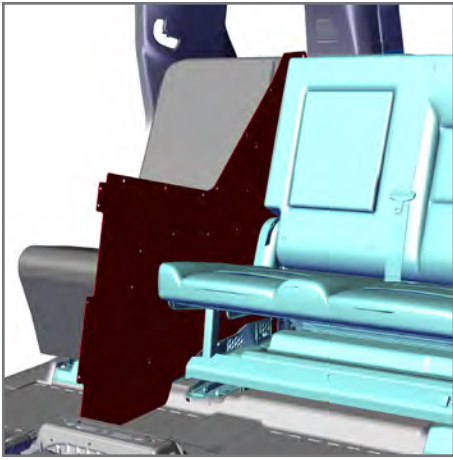

16. Slip the Lower Steel Center Divider between split in rear seats.



17. Install Assembled Front Divider into vehicle. This will require a little twisting to get into proper position. Bolt down Foot Mount Brackets to Assembled Front Divider with provided carriage bolts and flange nuts.

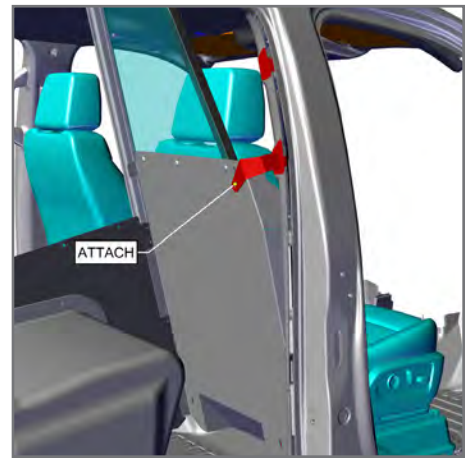

18. Loosely attach B Pillar Bracket onto Assembled Front Divider. Use provided carriage bolt and flange nut.

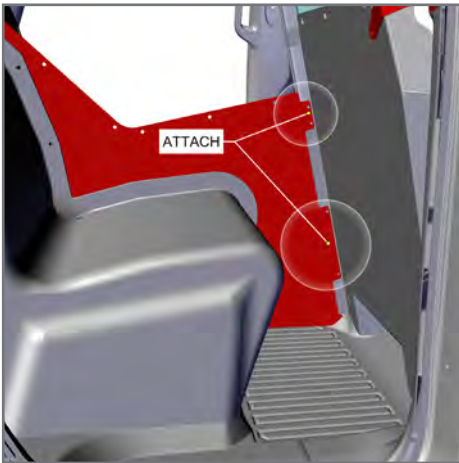

19. Loosely secure Lower Steel Center Divider onto Assembled Front Divider to the pre-positioned T-Blocks located in the rail of the Extruded Backbone with provided socket head cap screws.

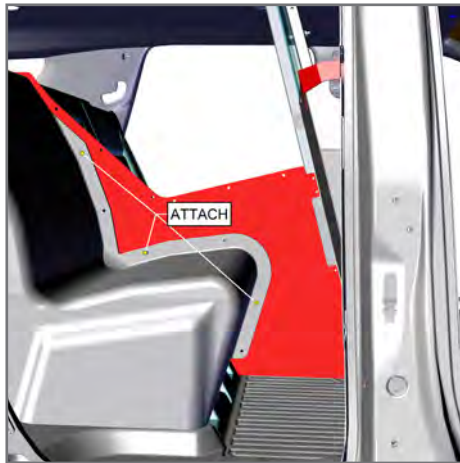

20. Secure the ABS Seat to the Lower Steel with provided flange nuts and carriage bolts.

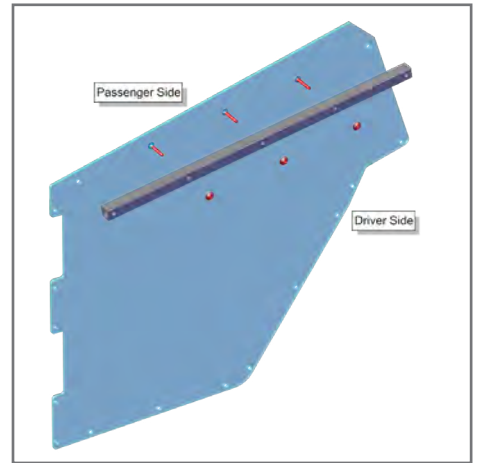

21. Outside of vehicle, attach the Stiffener Tube to the D/S Upper Poly Center Divider with provided carriage bolts and flange nuts.

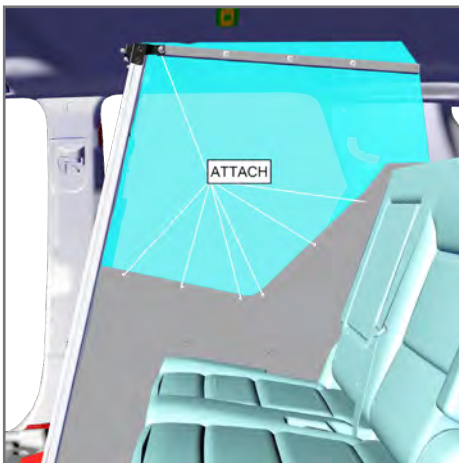

22. Attach Upper Poly Center Divider to Lower Steel Center Divider and Assembled Front Divider from P/S side using provided carriage bolts and flange nuts. Loosely tighten all bolts at this time.



23. Outside of vehicle, attach the Secure Grid to the Support Tubes with (4) carriage bolts and flange nuts.

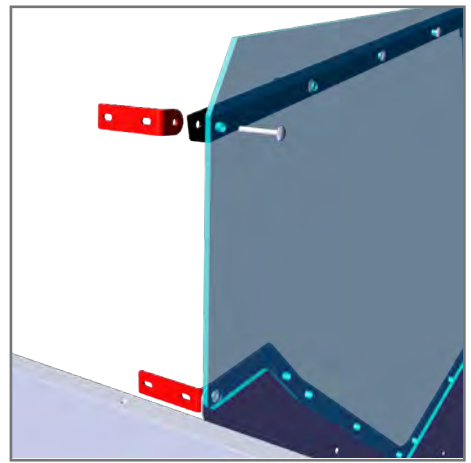

24. Attach the Secure Grid Bracket to the end of the Stiffener Tube and Lower Steel Divider with provided carriage bolts and flange nuts

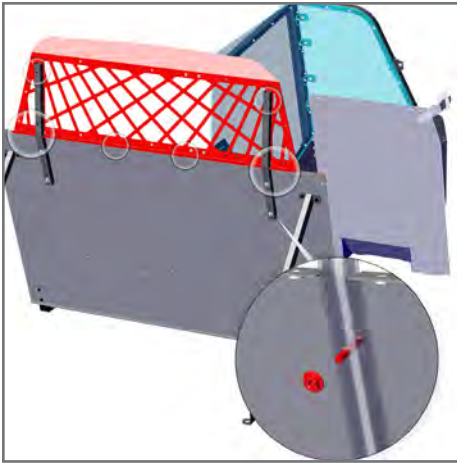

25. From cargo side of vehicle, attach the pre-assembled Secure Grid assembly to the Steel Panel with hex bolts and washers and Support Tubes with (4) carriage bolts and flange nuts.

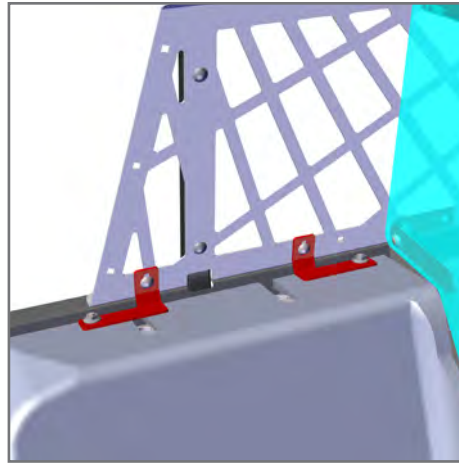

26. Attach the ABS Seat Brackets to the Secure Grid with provide carriage bolts and flange nuts.

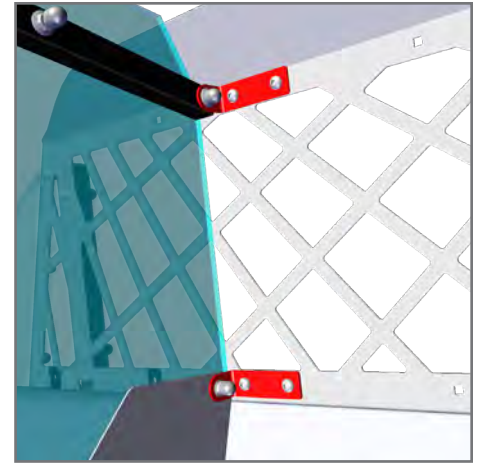

27. Secure Upper Poly Center Divider / Lower Steel Center Divider with previously attached Secure Grid Brackets to the Wire Grid on the Cargo Barrier with provided socket head cap screws.

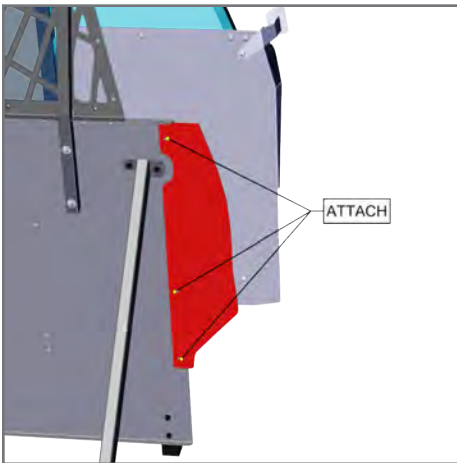

28. Install Lower DS/PS Side Wings with provided hex bolts and washers to the rear side of the Steel Panel.

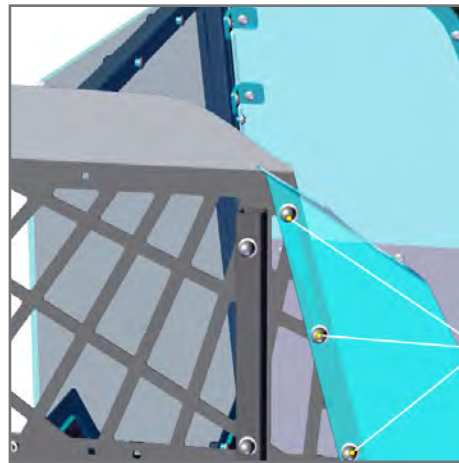

29. Install DS/PS Upper Side Poly Wings through the rear side of the Secure Grid with (3) carriage bolts with flange nuts.

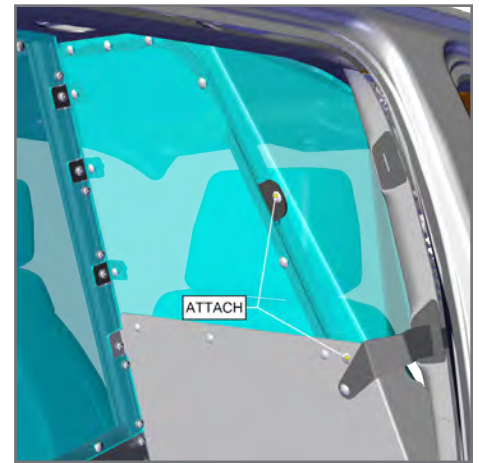

30. Install Upper Poly Wing from officer side and secure with provided carriage bolts and flange nuts. Install cap nut covers on all flange nuts.

**AT THIS POINT, CHECK FOR SQUARE AND TIGHTEN ALL HARDWARE INCLUDING OEM FRONT SEAT BOLTS.**

If you have questions or need further assistance please call Technical Support: 1.877.455.6886



209 W. EASY ST., ROGERS, AR 72756 • JOTTOPUBLICSAFETY.COM • 6/23

Jotto Desk™ is a patented product and Registered Trademark of Assembled Products™ Corporation.  
Specifications subject to change without notice.