



The Stash (Patent No.: US 11,554,772) was developed as a simple Single Weapon Storage Unit to be secured in the rear cargo area of a 2021+ Chevy Tahoe, 2020+ Ford PI Utility and in the trunk of a 2016+ Dodge Charger... while maintaining the majority of the cargo area for other storage needed in a patrol vehicle.

This unique and quick access solution comes standard with a padded, nylon scabbard to protect the weapon and help ensure optics stay true. The scabbard performs double duty by allowing officers/deputies to bring a black bag into their residence or a range vs. carrying an exposed patrol rifle.

For quick access, the door can be opened utilizing either of two provided momentary switches. The door to the Stash features spring hinges, so the press of a momentary switch releases the actuator and lock...allowing the door to swing open. One switch, mounted out of sight to the Stash housing, allows the weapon to be accessed or secured once the rear hatch/trunk has been opened. The other switch can be hidden for drivers use, allowing the button to be pushed...opening the door 1-2". Upon stopping, simply opening the rear hatch/trunk lid will allow the door to spring open the remaining way and allowing access to the weapon.



CHEVY TAHOE

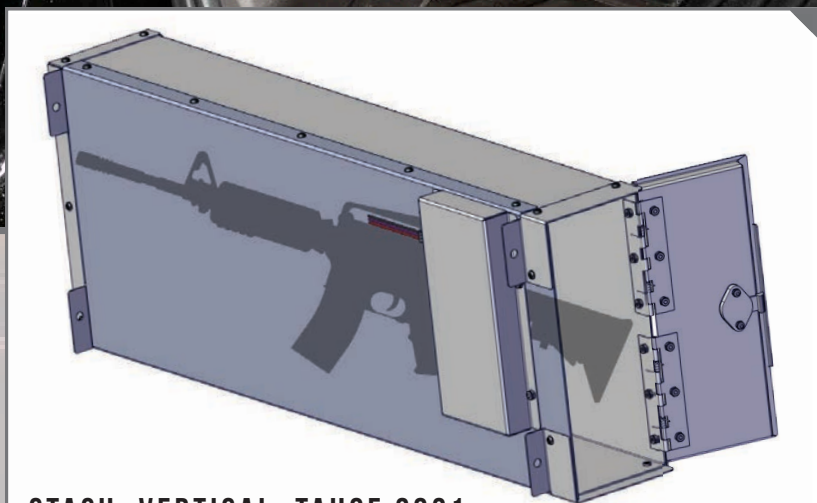

STASH, VERTICAL, TAHOE 2021+

475-2108



QUICK DISCONNECT



HINGED OPENING

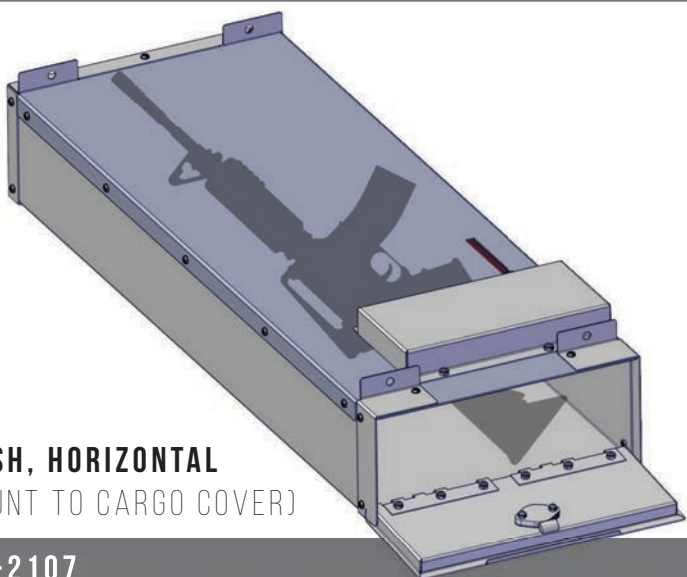

**STASH, HORIZONTAL
(MOUNT TO CARGO COVER)**

475-2107



FUSE/JACK ACCESS

FORD PI UTILITY

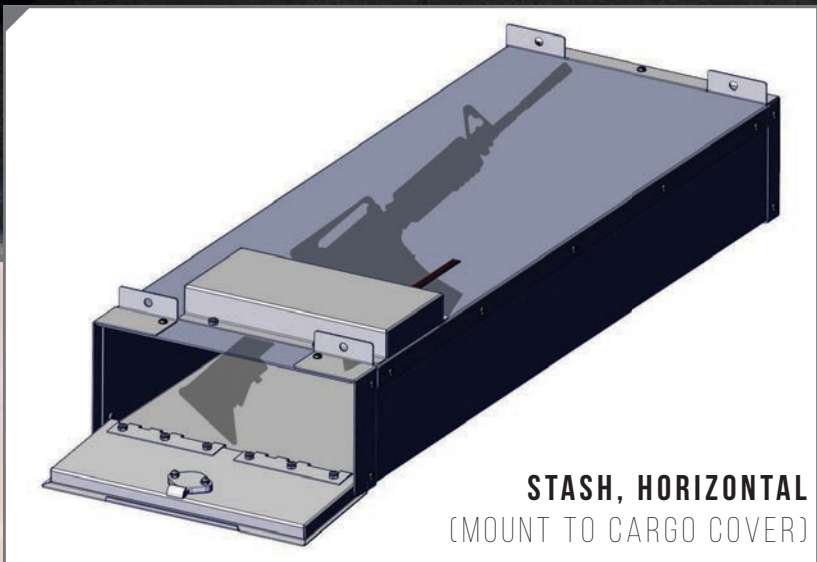

STASH, HORIZONTAL
(MOUNT TO CARGO COVER)

475-2107

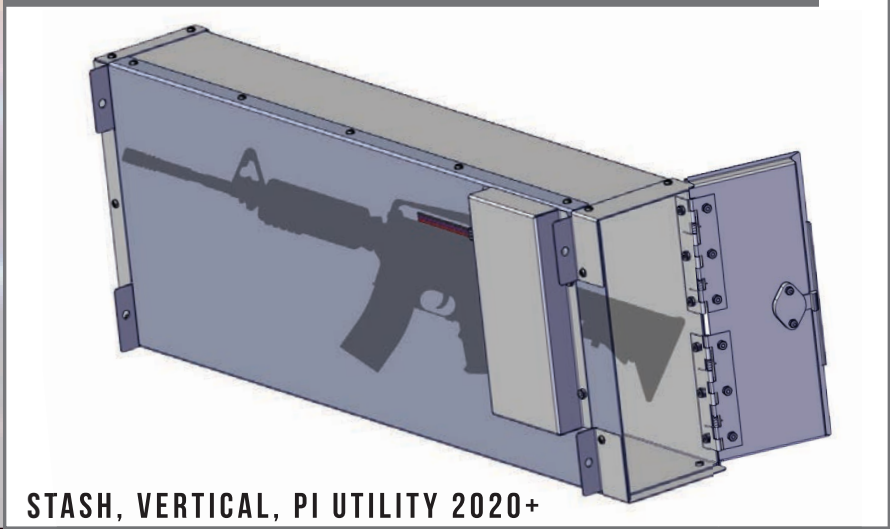

STASH, VERTICAL, PI UTILITY 2020+

475-2109

DODGE CHARGER

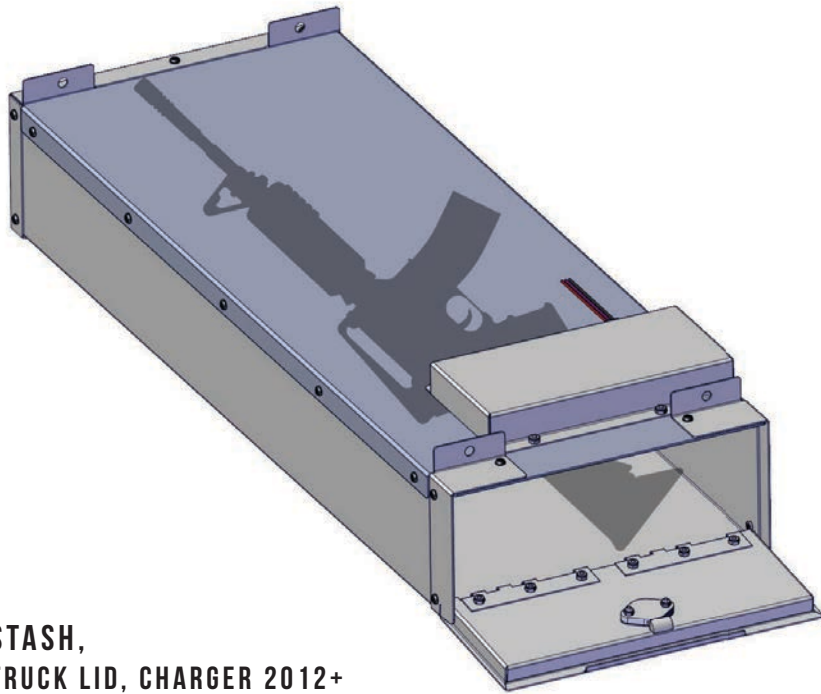

STASH,
TRUCK LID, CHARGER 2012+

475-2109



209 W. EASY ST., ROGERS, AR 72756 • JOTTOPUBLICSAFETY.COM • 10/23

Jotto Desk™ is a patented product and Registered Trademark of Assembled Products Corporation.
Specifications subject to change without notice.